

# Enabling Technologies and Benefits of Multi-Tenant Multi-Service 5G Small Cells

Ioannis Giannoulakis  
NCSR-D, Agia Paraskevi, Greece  
[giannoul@iit.demokritos.gr](mailto:giannoul@iit.demokritos.gr)

Jose Oscar Fajardo  
UPV/EHU, Bilbao, Spain  
[joseoscar.fajardo@ehu.eus](mailto:joseoscar.fajardo@ehu.eus)

Javier Garcia Lloreda  
Atos, Madrid, Spain  
[javier.garcial@atos.net](mailto:javier.garcial@atos.net)

Pouria Sayyad Khodashenas,  
Cristina Ruiz, August Betzler  
i2CAT, Barcelona, Spain  
[pouria.khodashenas@i2cat.net](mailto:pouria.khodashenas@i2cat.net)

Emmanouil Kafetzakis  
ORION INNOVATIONS, Greece  
[mkafez@orioninnovations.gr](mailto:mkafez@orioninnovations.gr)

Jordi Pérez-Romero  
UPC, Barcelona, Spain  
[jorperez@tsc.upc.edu](mailto:jorperez@tsc.upc.edu)

Antonino Albanese  
ITALTEL, Castelletto, Milan, Italy  
[antonino.albanese@italtel.com](mailto:antonino.albanese@italtel.com)

Michele Paolino  
Virtual Open Systems, Grenoble, France  
[m.paolino@virtualopensystems.com](mailto:m.paolino@virtualopensystems.com)

Leonardo Goratti, Roberto Riggio  
CREATE-NET, Trento, Italy  
[leonardo.goratti@create-net.org](mailto:leonardo.goratti@create-net.org)

**Abstract**—In this manuscript, we present the main concepts of the 5G-PPP SESAME project dedicated to the implementation of Cloud-Enabled Small Cells (CESCs), able to support edge cloud computing in a multi-tenant, multi-service ecosystem. More particularly, we give a preview of the SESAME concept at the component/sub-system, system and operation level. At the component/sub-system level, we detail our plan to deploy multi-operator enabled small cells, enhanced with a virtualised execution platform for 5G. At the system level, we present the envisaged architecture to manage and control the cloud-enabled small cell infrastructure. Finally, at the operation level, we explain the potential advantages of adopting the SESAME concept on the 5G access networks.

**Keywords**—NFV and edge cloud computing; small cell; multi-tenancy; 5G networks

## I. INTRODUCTION

5th generation mobile networks (5G) demands key features beyond what the current 4G can offer, such as significantly higher wireless capacity, reduced energy consumption per service, and reliable connectivity with very low latency [1]. However, to deliver a viable solution meeting all 5G requirements, a substantial change on the mobile network paradigm is inevitable.

Traditionally, to provide coverage in one Point of Presence (PoP), actual installation of physical infrastructure, e.g. Small Cell (SC), is needed. Despite the fact that mounting equipment in one place may not be possible (e.g. dense areas), such an ownership increases operators' CAPEX and significantly hampers business agility, particularly when considering the high degree of cell densification needed to deal with the 5G requirements. Moreover, the static nature of physical ownership makes it difficult (impossible in some cases) to handle scenarios with dynamic capacity requirements. For example, a flash crowd event at a venue (e.g., stadium, urban area, etc.) cannot be well-served without overprovisioning of the underlying physical infrastructure. It can be easily translated to more operators' expenses (CAPEX and OPEX), which in turn increases the service cost for the end users. To address this issue, the idea of

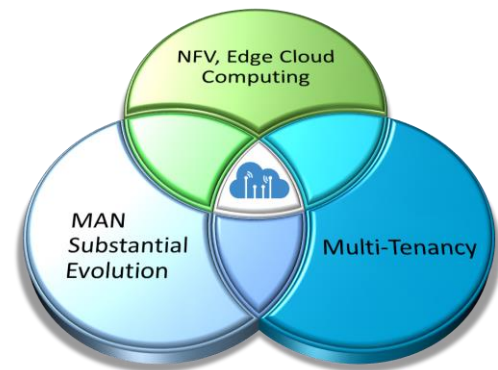

Fig. 1. SESAME concept.

multi-tenancy has been initiated in 3GPP [2] and it is expected to play a vital role in 5G networks. In a multi-tenant scenario, a third party owns the underlying infrastructure and provides access to the actors of the telecom scene like network operators, service providers, Over-the-Top players and so on. Such a sharing increases service dynamicity and reduces the overall cost and energy consumption.

Furthermore, although nowadays new stakeholders enter the network value chain at an increasing pace, network equipment deployed at the edge and access networks are specialized devices with 'hard-wired' functionalities. Any adaptation to the ever increasing and heterogenous market requirements means a huge investment to change/deploy hardware. Thanks to the advent of cloud computing, Software Defined Networking (SDN) and Network Function Virtualisation (NFV), the idea of having general-purpose computing and storage assets at the edge of mobile networks has emerged. It is a substantial change on the architecture of current Mobile Access Nodes (MAN), from being only a wireless head to cloud-enabled device equipped with, e.g., novel processor architectures, Graphics Processing Units (GPU), Digital Signal Processors (DSP), and/or Field-Programmable Gate Arrays (FPGA). In this line, new industry initiatives have already introduced the concept of Mobile-Edge Computing (MEC) [3] and the related key market drivers [4].

To address the abovementioned issues, SESAME concept [5] has focused on innovations at the intersection of technologies as depicted in Fig. 1: the placement of network intelligence and applications in the network edge through NFV and MEC, the substantial evolution of the SC towards cloud-based coordinated management, and the consolidation of multi-tenancy in mobile communications infrastructures.

The resulting solution will allow several operators/service providers to engage in new sharing models of both access capacity and edge computing capabilities, i.e. promoting the concept of Small Cells-as-a-Service (SCaaS) based on the conceptual model of ‘network slicing’ –the logical partitioning of the localized network infrastructure in one PoP.

In this paper, we review the implementation of Cloud-Enabled Small Cells (CESCs), able to support edge cloud computing in a multi-tenant, multi-service ecosystem. To this end, the SESAME concept is presented in three levels: the component/sub-system, system, and operation level. Section II focuses on the component/sub-system level and details the enabling technologies to deploy multi-operator enabled small cells, enhanced with a virtualised execution platform for 5G. Section III deals with the system level and presents a preliminary architecture to manage and orchestrate the cloud-enabled small cell infrastructure. Section IV details the operation level and explains the potential advantages of adopting the SESAME concept on the 5G access networks. Finally, in Section V we present our conclusions.

## II. ENABLING TECHNOLOGIES

### A. Cloud-enabled Small Cell

The concept of CESC is the key enabler in order to form a cloud-enabled platform that supports both radio access and edge computational services at one PoP. It foresees the split of the small cell into physical and virtual network functions [6][7], respectively Physical Network Function (PNF) and Virtual Network Function (VNF), enabling a multi-tenancy environment to support the Multi-Operator Core Network (MOCN) requirements [2]. The hosting of VNFs related to small cell virtualised functions, as well as service VNFs (e.g. virtual Deep Packet Inspection –vDPI) is guaranteed by the design of an advanced modular micro server whose architecture and characteristics are optimized for the MEC environment. The micro server and small cell co-location is one fundamental requirement taken into account in the design. The architecture of the micro server is based on a very efficient System on Chip (SoC) that includes multi-core ARMv8 64 bit CPU and hardware (HW) accelerators dedicated to networking and packet processing. The choice of ARM, instead of a traditional x86 architecture, allows to optimize power consumption, in particular for relatively light workloads. In case of additional computational requirements (e.g. audio and video transcoding, security features, crypto engines), the micro server is able to host standard PCI Express (PCIe) cards equipped with various kinds of HW accelerators (FPGAs, DSPs, GPUs). Moreover, when capacity storage is needed (e.g. for video caching), one or more micro servers can host a disk controller with the related disks. It is also worth to mention that the micro server provides a fronthaul connection towards the 5G radio head – SC PNF.

### B. Light Data Centre

The CESCs clustering enables the achievement of a micro scale virtualised execution infrastructure in the form of a distributed data centre, denominated Light Data Centre (Light DC), enhancing the virtualisation capabilities and process power at the network edge. The HW architecture of the Light DC envisages that each micro server will be able to communicate with all others via a dedicated LAN guaranteeing the latency and bandwidth requirements needed for sharing resources. Such a clustering is achieved using a standard Ethernet switch, suitably configured for properly enabling the networking between CESCs (bandwidth management, VLAN separation, etc.). It provides also the backhaul connections to the operators Evolved Packet Core (EPC) and all the links to the management system of the SESAME platform.

Network Services (NS) are supported by VNFs hosted in the Light DC (constituted by one or more CESC), leveraging on technologies like SDN and NFV that allow to achieve an adequate level of flexibility and scalability at the cloud infrastructure edge. More specific, VNFs are executed as virtual machines (VMs) inside the Light DC, which is provided with a hypervisor (a Kernel-based Virtual Machine (KVM)-like solution) specifically extended to support carrier grade computing and networking performance. To achieve high performance at low cost and power consumption, the proposed hypervisor computing extensions enable VMs access to HW accelerators. Depending on the specific use case, the VMs are connected with these accelerators by using direct device assignment or Application Programming Interface (API) remoting. Furthermore, to offer high networking bandwidth and speed, each micro server runs a performance optimized user space virtual switch and leverages on specific zero copy shared memory extensions for the communication between VNFs co-hosted on the same Light DC (VM to VM). Moreover, the portability of the accelerated VNFs is improved by adopting specific open source standardization APIs such as Open Data Plane (ODP) and Open Fast Path (OFF).

## III. MULTI-TENANT MULTI-SERVICE MANAGEMENT AND ORCHESTRATION

### A. Cloud-enabled Small Cell Manager

The Light DC concept is going to offer a virtualisation platform to meet 5G requirements summarized in Fig. 1, namely NFV-driven small cell functions, NFV-based multi-tenancy and NFV-based MEC services. However, management and orchestration of this uniform virtualised environment, able to support both radio connectivity and edge services, is a challenging task by itself. From a pragmatic perspective, to better suggest a solution, we need to first understand the nature of VNFs and services under the scope of SESAME. In light of this, two types of VNFs are identified:

- SC VNFs: associated to the virtualised execution of different functionalities of the SC. SC VNFs may represent different layers of the E-UTRAN protocol stack, while the rest of protocol entities will remain as PNF. The use of SC VNFs offers the required support for splitting the SC resources in different virtual slices provided to different tenants (multi-tenancy).

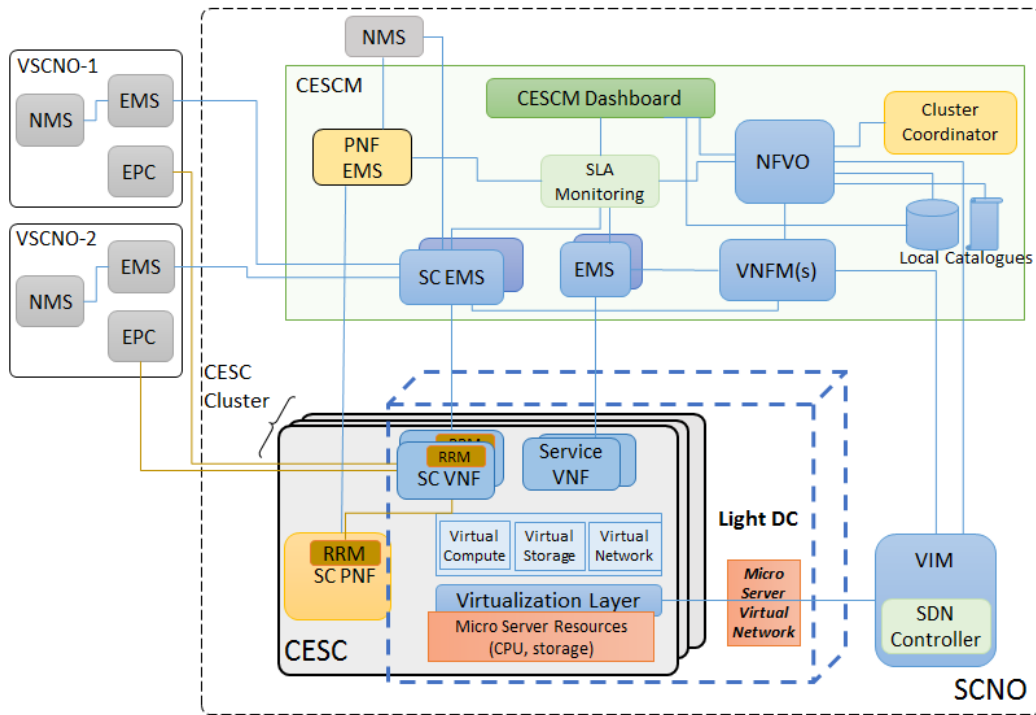

Fig. 2. Block diagram of overall SESAME architecture.

- Service VNFs: targeting the key performance indicator (KPI) of 5G, e.g., low latency through the proximity of end users and the serving nodes, service VNFs (e.g., virtual firewall and virtual caching) are instantiated on the Light DC.

Over the provided virtualised execution environment (Light DC), it is possible to chain different VNFs to meet a requested NS by a tenant (i.e. mobile network operator). Note that, in the context of SESAME, a NS is understood as a collection of VNFs that jointly supports data transmission between User Equipment (UE) and operators' EPC, with the possibility to involve one or several service VNFs in the data path. Therefore, each NS is deployed as a chain of SC VNFs and Service VNFs. It clearly highlights that, beyond the conventional orchestration and management of the cloud resources in a virtualised environment, the proposed solution entails a series of specific challenges such as the dynamic composition of the Light DC resources based on the status of CESC cluster(s), coordination of specific type of resources (radio-related resources, service-related HW accelerators, etc.) and isolation of dedicated network slices to each tenant.

Having all these principles in mind, Fig. 2 illustrates the envisaged high level architecture of the SESAME solution containing the main building blocks and their internal/external interconnections. The Small Cell Network Operator (SCNO) is the owner of the radio access infrastructure, and offers the sliced NS to the Virtual Small Cell Network Operator (VSCNO), which acts as tenant mobile network operator.

The CESC Manager (CESCM) is the central service management and orchestration component in the architecture. Generally speaking, it integrates all the traditional 3GPP network management elements, and the novel recommended functional blocks to realize NFV [8]. A single instance of

CESCM is able to operate over several CESC clusters, each constituting a Light DC, through the use of a dedicated Virtual Infrastructure Manager (VIM) per cluster. Note that, due to the distributed nature of the Light DC, the proposed VIM requires data packet extraction (from the traditional 3GPP data path) and a forwarding rule implementation to guarantee possible communication between SC VNFs and Service VNFs (may reside in different CESC). SDN principles are used to endow the system with the required scalability. In this way, the CESC instructs the embedded SDN controller at VIM with the specific VNF forwarding rules, and the SDN controller in return applies them to support the desired connectivity within the Light DC.

For each instantiated VNF, an Element Management System (EMS), deployed in the CESC, is responsible to carry out key management functionalities –fault monitoring, configuration, accounting, performance monitoring and security (FCAPS). Meanwhile, the SCNO Network Management System (NMS) is the central management point for the whole network of the SCNO, while the PNF EMS and the SC EMS are respectively in charge of the management of the physical and virtualized network functions residing at the SC.

The lifecycle management of deployed VNFs is carried out by the VNF Manager (VNFM) included in the CESCM. By leveraging on the monitoring mechanisms, the CESCM, in conjunction with the VNFM, is able to apply policies for NS-level rescaling and reconfiguration to achieve high resource utilization. It is worth to mention that monitoring mechanisms are dictated by the CESCM Service Level Agreements (SLA) monitoring unit that allows the monitoring of SLAs between different business role players, i.e. SCNO and VSCNOs.

Another essential component at the heart of CESCM is the NVF Orchestrator (NFVO). Besides management and orchestration of the abovementioned functionalities, NFVO

composes service chains (constituted by two or more VNFs located either in one or several CESC) and manages the deployment of VNFs over the Light DC. This includes not only the management of a typical Network Function Virtualization Infrastructure (NFVI) (i.e. processing power, storage and networking), but also assignment of HW accelerators. Besides, to improve the energy efficiency of the proposed solution, NFVO may need to take care of switching on and off resources at CESC level.

The CESC Dashboard includes two login procedures. A login for the VSCNO tenants aims to provide SLA monitoring information and an entry point to browse NS and VNF catalogues. Another login for the SCNO administrator to register extra resources and add new VNFs to the CESC catalogues. In this scenario, any request for a new VNF by a tenant needs to be directly submitted and communicated with the SCNO administrator. After an agreement between both parties, the VNF will be implemented and registered to the VNF catalogue by the administrator and can be inserted on the service chains.

### B. Self-x Features

A key challenging issue to face on SESAME is the overall optimal configuration of the CESC infrastructure, in light of the complex future scenarios envisaged for 5G, with heterogeneity existing at different levels (e.g. multiple spectrum bands, multiple types of devices and services, etc.). This claims for an evolution of current methodologies for RAN planning and optimization, by introducing a higher degree of automation that fully exploits cognitive capabilities. In this direction, legacy systems such as 3G/4G already started this path with the introduction of Self-Organizing Network (SON) functionalities, also referred to as self-x functionalities [9]. They consist of a set of features and capabilities designed to reduce or remove the need for manual activities in the lifecycle of the network, so that operating costs can be reduced as well as revenue can be protected by minimizing human errors. The SESAME solution will leverage on the use of these capabilities to achieve an optimized management of the deployed CESC.

SON functions in SESAME will be organized around three main categories: (i) Self-planning, which involves the automatization of the process of deciding the need to roll out new CESC in specific areas, proposing configurations and settings of the new network nodes, as well as proposing capacity extensions for already deployed nodes (e.g. by provisioning additional carriers in either licensed or unlicensed bands), with the target of ensuring the specific SLAs with the tenants. (ii) Self-optimization, which includes the processes to improve or maintain the network performance by tuning the settings of the deployed CESC. It involves different functions, such as Inter-Cell Interference Coordination (ICIC), Mobility Load Balancing, Automatic Neighbour Relations (ANR) to discover and list neighbour cells, optimization of admission control/congestion control and packet scheduling parameters, energy saving mechanisms, etc. (iii) Self-healing, which involves the processes related to fault management and fault correction, in order to keep the CESC operational and prevent disruptive problems.

From an architectural perspective, several possibilities exist for the location of the self-x functionalities in the SESAME

architecture of Fig. 2: they can be either centralized at the EMS or the NMS or they can be decentralized at the CESC, and in the latter case they can be implemented either as PNFs or VNFs. The choice of one option or the other will depend on aspects such as the required time scale of operation, the required degree of coordination or the computational requirements. In addition, the specificities of the SESAME approach bring relevant challenges for the development of self-x functions in relation to traditional networks. (i) First, SESAME self-x functions need to operate in a multi-tenant scenario. Therefore, a differentiation has to be done between those functions that are common to all the tenants, so they fall under the domain of the SCNO, and those that should be executed separately per tenant. This differentiation will be dependent on how the SLAs are defined between the SCNO and the tenants. (ii) Second, the introduction of NFV capabilities in the small cells allows that some self-x functions can be implemented as VNFs, thus benefiting from enhanced flexibility and higher processing capabilities thanks to exploiting the computational resources available at the multiple micro servers composing the Light DC. (iii) SESAME self-x solutions will benefit from the application of Artificial Intelligence (AI)-based tools to process and analyse different types of available input data (e.g. network data, user data, etc.) in order to come up with exploitable knowledge that will be used to drive the decisions of the self-x functionalities.

### C. VNF Placement and NS scaling

In a heterogeneous radio/IT environment, like the one proposed in SESAME, some important management tasks such as the way that physical and virtual resources are mapped together and the NS scaling need to be handled in a more precise and comprehensive manner. As stated above, these tasks in general are carried out automatically by the CESC and in particular by the NFVO, which implies the utilization of global and local optimization methods. In this section, instead of going deep on a specific solution and its explanation, we try to draw a general picture of the SESAME VNF placement and scaling tasks requirements.

The VNF placement problem has recently grabbed some attention on the literature [11][12][13]. As stated in the references, a possible way to tackle the VNF placement consists of the graph embedding techniques, which in principle is a NP-hard problem. Like any NP-hard problem, besides the time consuming and complex Integer Linear Programming (ILP) solutions, it is possible to approximately solve the VNF placement problem with heuristic algorithms. Generally speaking, the problem of placing virtual resources (i.e. VNFs and related VMs) over the physical infrastructure can be solved considering different objectives ranging from the minimized overall energy consumption to minimized virtual resource consumption. Depending on the targeted objective and the way that the problem is formulated, flow paths have to be modified accordingly. The task of VNF placement becomes even more challenging in a setting such as that of SESAME, where the underlying CESC are meant to be shared by different VSCNOs. In this respect, the performance isolation problem between tenants has to be also addressed. Moreover, a comprehensive SESAME solution besides mapping VNFs on the conventional IT resources (general processor, storage and networking) needs to manage and allocate HW accelerators depending on the

service type and use cases.

Conceptually, similar to the VNF placement problem, the NS scaling also needs a precise decision making procedure. That may include resilient and cognitive solutions, depending on the targeted use case. In this case, one or more VNFs involved in a service chain can dynamically be scaled up and down according to the actual traffic conditions. This can be easily translated to energy and resource efficiency. As stated earlier, this feature is one of the key advantages of NFV as opposed to the vertically integrated middle boxes where scaling up and down a network function essentially implies interfering with the real HW. A possible solution for the NS scaling problem needs to have some key elements on the scope such as the process triggering threshold (when and how to start the NS scaling procedure), the scaling process structure, compliancy of scaling steps with the agreed SLA, etc.

#### IV. EXPECTED BENEFITS

It is expected that in the framework of SESAME the speed of service delivery significantly increases, since the edge cloud services are executed very near to the end user. It creates an excellent opportunity for stakeholders, e.g. operators and cloud based platforms, to serve customers (individuals and businesses) demand for intelligence and complex services in a practical and latency-free manner. Also, multi-tenancy achieved through the virtualisation of network resources, as a key ingredient of the SESAME concept, allows efficient use of deployed physical infrastructure at one PoP, via the on-demand network topology changes (e.g. add/drop of CESC to a cluster) and elastic per-tenant capacity allocation, aiming to guarantee the Quality of Experience (QoE) and reduce the total cost of operation. Having this in mind, compared to the current 4G systems, some of the SESAME merits can be listed as follows:

- Higher wireless area capacity and more varied service capabilities: by deploying high-density multi-service multi-tenant SC networks higher traffic and capacity per geographical areas are supported.
- Reducing the average service creation time: the flexible design of the CESC platform and the associated management layers promotes a shared virtualized infrastructure, i.e. a cloud environment, right at the network's edge which reduces the service deployment time scale.
- Creating a secure, reliable and dependable Internet with a "zero perceived" downtime for services provision: by definition, SESAME allows rapid integration of multiple virtual operators sharing the CESC provider's infrastructure, thus allowing isolated and secure provision of vertical services for massive amount of connected devices. Also, automated network resource monitoring/optimization allows to provision them where they are needed the most, i.e. resource rebalancing/repurposing. It guarantees service reliability and minimizes service downtime.

The expected benefits are evidenced through a set of different use cases detailed in [14] which fall into three main categories: (i) multitenancy in predefined venues, (ii) mobility

and 'blind spots' support, and (iii) sporadic flash crowd events.

#### V. CONCLUSION

In order to address the needs and requirements of 5G for a robust and agile network management, built upon the pillars of network functions virtualisation, mobile-edge computing and cognitive management, SESAME concept targets the development and demonstration of an innovative architecture, promoting the concept of SCaaS. To that end, SESAME envisages to virtualise and to partition small cell capacity, while at the same time it aims to support enhanced edge cloud services by enriching small cells with micro servers. This paper is an effort to detail enabling technologies, management/orchestration issues and challenges related to the heterogeneous radio/IT environment and some expected benefits of the SESAME concept.

#### ACKNOWLEDGMENT

The research leading to these results has been supported by the EU funded H2020 5G-PPP project SESAME under the grant agreement no 671596.

#### REFERENCES

- [1] "5G Infrastructure Public Private Partnership (PPP): The next generation of communication networks will be 'Made in EU'", European Commission, Digital agenda for europe, February 2014.
- [2] "Network sharing; Architecture and functional description", 3GPP TS 23.251 v12.0.0, Release 12, December, 2013.
- [3] "Mobile-edge computing: Introductory technical white paper", European Telecommunications Standards Institute (ETSI), 2014.
- [4] I. Son, D. Lee, J.-N Lee and Y. B. Chang, "Market Perception on Cloud Computing Initiatives in Organizations: An Extended Resource-based View", *Information & Management*, vol. 51, no. 6, 2014.
- [5] I. Giannoulakis, G. Xylouris, E. Kafetzakis, M. A. Kourtis, J. O. Fajardo, P. S. Khodashenas, A. Albanese, H. Mouratidis and V. Vassilakis, "System architecture and aspects of SESAME: Small cells coordination for Multi-tenancy and Edge services," submitted to IEEE ICC, 2016.
- [6] "Virtualization in Small Cell Networks", SCF154.05.02, Small Cell Forum, 2015.
- [7] "Business case elements for small cell virtualisation", SCF158.05.1.04, Small Cell Forum, 2015.
- [8] "NFV Management and Orchestration - An Overview", GS NFV-MAN 001 V1.1.1, European Telecommunications Standards Institute (ETSI), 2014.
- [9] "Telecommunication Management; Self-Organizing Networks (SON); Concepts and Requirements," 3GPP TS 32.500 V10.0.0, June 2010.
- [10] "Network Functions Virtualization (NFV); Management and Orchestration," ETSI GS NFV-MAN V1.1.1, Dec, 2014.
- [11] R. Riggio, A. Bradai, T. Rasheed, J. Schulz-Zander, S. Kuklinski and T. Ahmed, "Virtual Network Functions Orchestration in Wireless Networks," in Proc. of IEEE CNSM, 2015.
- [12] X. Lin and C. Qian, "The Virtual Network Function Placement Problem," INFOCOM 2015 Workshop, 2015.
- [13] S. Clayman, E. Maini, A. Galis, A. Manzalini and N. Mazzocca, "The Dynamic Placement of Virtual Network Functions," in Proc. of IEEE NOMS, May 2014.
- [14] 5G-PPP H2020 Call SESAME project, deliverable D2.1 [Online], available: <http://www.sesame-h2020-5g-ppp.eu/>